

Integral Bonnet Needle Valves



Integral Bonnet
Needle Valve

Applications & Features:

- Designed for Instrument air lines, panels, Test Stands & Analytical systems
- General flow control service
- Designed for regulation and tight shut off
- Compare with Swagelok O, 1 and 18 Series Integral Bonnet Needle Valves
- Panel Mountable
- Live-Loaded, Chevron-Style packing
- Stainless Steel Construction
- Packing Material: PTFE
- Flow coefficient (Cv) 0.30 to 1.80
- Integral tube fitting (both double & single ferrule designs)
- 100% factory tested with nitrogen at 1000 psi



Integral Bonnet
Needle Valve

Temperature (F°)	Pressure (psig)
-60	5000
0	5000
100	5000
190	5000
200	4750
300	3000
400	1250
400	0

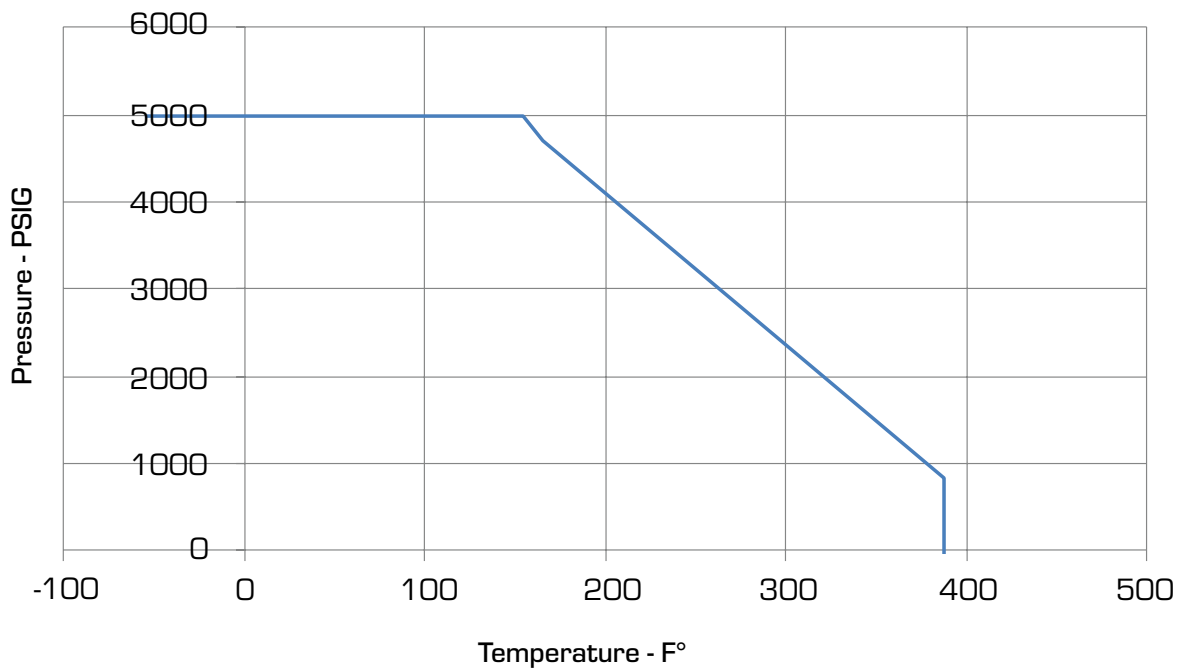

Integral Bonnet Needle Valves

Item	Component	Materials
1A	Tee Handle*	Aluminum
1B	Round Handle	Black Phenolic
1C	Handle Pin	Stainless
2	Set Screw	316 SS
3	Packing Nut	304 SS
4	Gland	304 SS
5	Packing Springs	304 SS
6	Packing Gland	304 SS
7	Upper Packing	TFM 1600 PTFE (Polytetrafluoroethylene)
8	Lower Packing	
9	Lower Gland	316 SS
10	Stem	Chrome-plated 316 SS
11	Panel Nut	304 SS
12	Body	316L SS
13	Front Ferrule	316L SS
14	Rear Ferrule	316L SS
15	Nut	316L SS

* 1RB Series valve are only available with Tee (Bar) handles

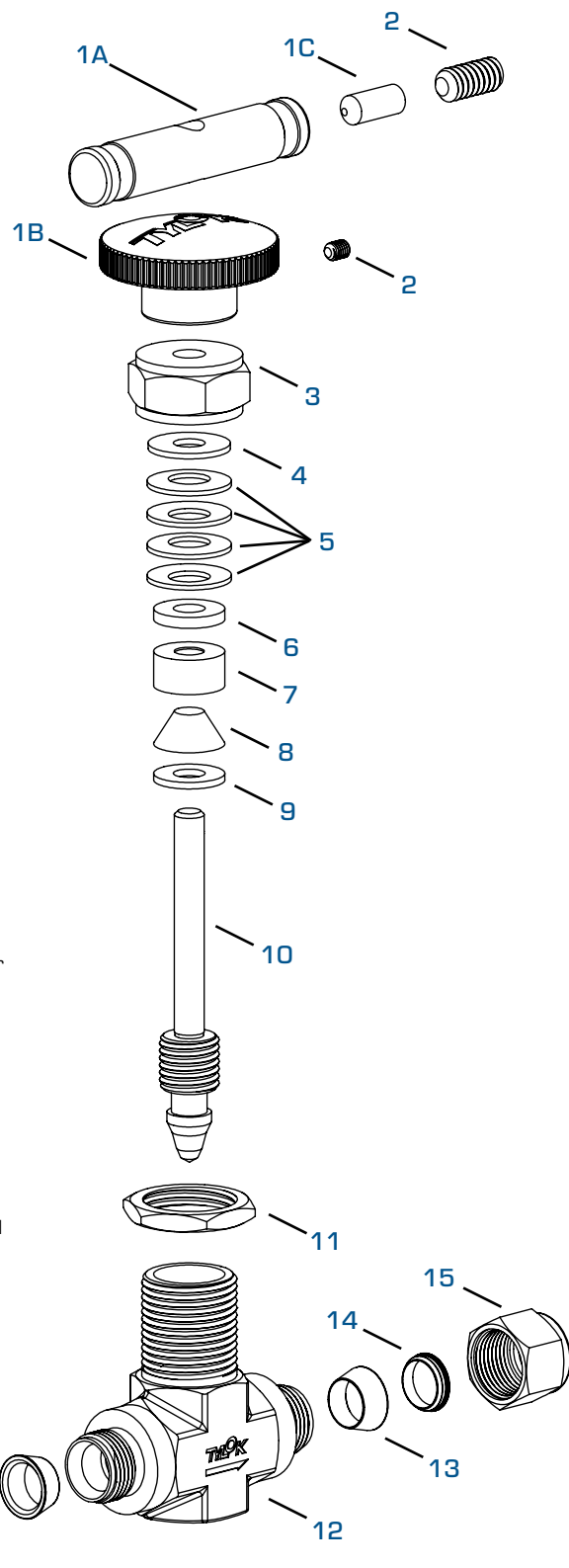

Integral Bonnet
Needle Valve

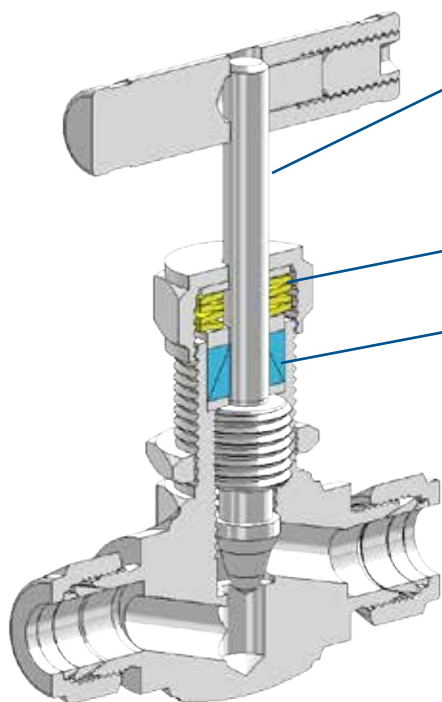

Chevron (2) piece sliding provides improved ID/OD sealing and wear compensation.

Belleville washers provide active compensation for wear, improved sealing and reduce manual adjustment.

Stem chrome plated for wear and corrosion resistance.

Integral Bonnet Needle Valves

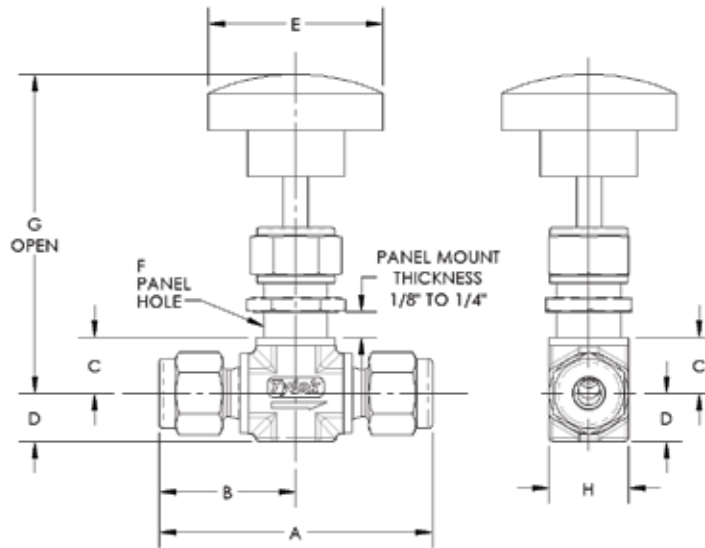

End Connections		Part Number	Interchanges With	Cv	Orifice	A	B	C	D	E	F	G	H
Type	Size												
CBC-Lok® Tube Fitting	1/4	SS-1R4-D4D4	SS-1RS4	0.37	0.158	2.27	1.13	0.44	0.41	1.38	0.53	2.50	0.63
	3/8	SS-1R6-D6D6	SS-1RS6	0.73	0.250	2.58	1.29	0.50	0.56	1.88	0.78	2.97	0.88
	1/2	SS-1R6-D8D8	SS-1RS8	0.73	0.250	2.80	1.40	0.50	0.56	1.88	0.78	2.97	1.13
	1/2	SS-1R8-D8D8	SS-18RS8	1.80	0.375	3.80	1.90	0.75	0.75	3.00	1.03	3.91	1.13
	3/4	SS-1R8-D12D12	SS-18RS12	1.80	0.375	3.80	1.90	0.75	0.75	3.00	1.03	3.91	1.13
CS-Lok® Tube Fitting	1/4	SS-1R4-S4S4	N/A	0.37	0.158	2.27	1.14	0.44	0.41	1.38	0.53	2.50	0.63
	3/8	SS-1R6-S6S6	N/A	0.73	0.250	2.60	1.30	0.50	0.56	1.88	0.78	2.97	0.88
	1/2	SS-1R6-S8S8	N/A	0.73	0.250	2.81	1.40	0.50	0.56	1.88	0.78	2.97	1.13
	1/2	SS-1R8-S8S8	N/A	1.80	0.375	3.80	1.90	0.75	0.75	3.00	1.03	3.91	1.13
	3/4	SS-1R8-S12S12	N/A	1.80	0.375	3.80	1.90	0.75	0.75	3.00	1.03	3.91	1.13
Male NPT to CBC-Lok®	1/4	SS-1R4-M4D4	SS-1RM4-S4	0.37	0.158	1.95	0.82	0.44	0.38	1.38	0.53	2.50	0.63
Male NPT to CS-Lok®	1/4	SS-1R4-M4S4	N/A	0.37	0.158	1.95	0.82	0.44	0.38	1.38	0.53	2.50	0.63
Female NPT	1/4	SS-1R6-F4F4	SS-1RF4	0.73	0.250	2.12	1.06	0.55	0.50	1.88	0.53	2.97	0.63
	3/8	SS-1R8-F6F6	SS-18RF6	1.80	0.375	3.00	1.50	0.75	0.75	3.00	1.03	3.88	1.13
	1/2	SS-1R8-F8F8	SS-18RF8	1.80	0.375	3.00	1.50	0.75	0.75	3.00	1.03	3.88	1.13
Male NPT to Female NPT	1/4	SS-1R6-M4F4	SS-1RM4-F4	0.73	0.250	2.19	1.13	0.50	0.50	1.88	0.53	2.97	0.63
	1/2	SS-1R8-M8F8	SS-1RM8-F8	1.80	0.375	3.00	1.50	0.75	0.75	3.00	1.03	3.88	1.13

Note: In designing a system incorporating tube fittings and valves, it is the designer's or user's obligation and responsibility to determine the appropriate fittings and valves to be used for each application and to ensure proper installation and maintenance.